

Servo im Fahrerhaus:

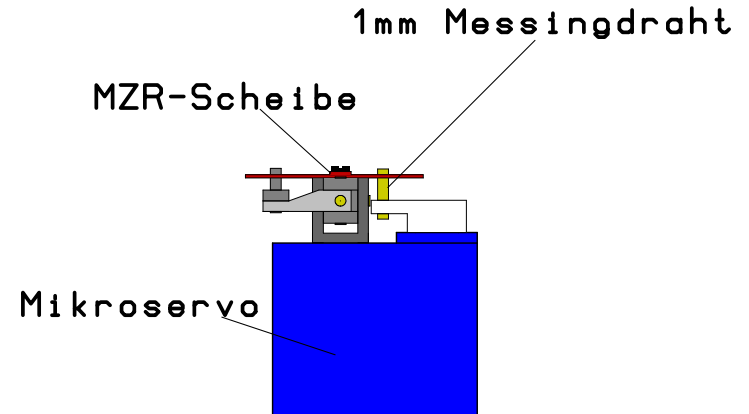

Bearbeitungsbeispiel

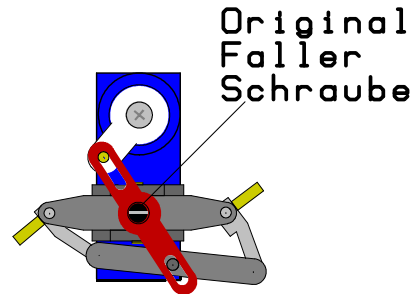
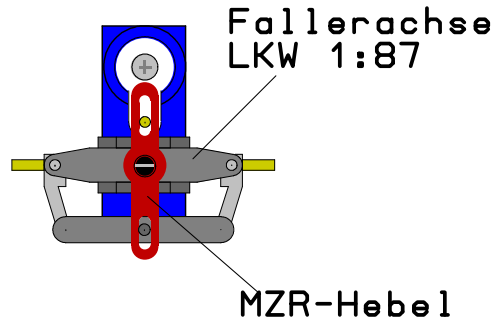

Montagebeispiel mit Kupferbuchse

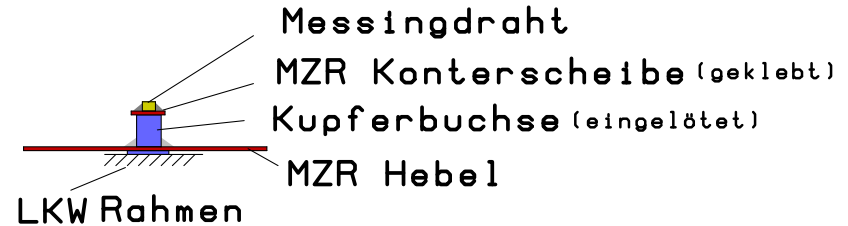

Servo auf Ladefläche:

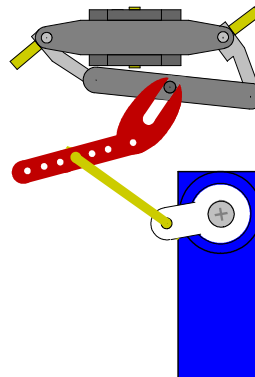
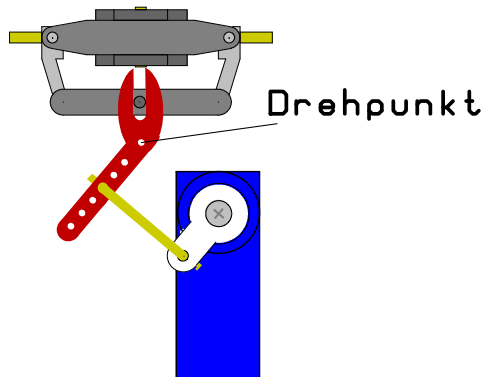

Datum	Version	Hebel für Anlenkung	
04.2009	Hebel 01		
M	Material: Neusilber	Andreas Rackel	Blatt 1
7:1			